



iSWITCH

SISTEMAS DE GESTIÓN DE ENERGÍA ENERGY MANA- GEMENT SYSTEMS

iTOUCH- lift button activator- capacitive

The button enables us to call the lift by approaching the hand.
Our products are designed to meet the needs of the following
markets:
hotels, hospitals, retirement homes, student housing, universities, office or government buildings.....

WE MAKE
SENSE

ENKOA





ISWITCH ITOUCH - LIFT BUTTON ACTIVATOR CAPACITIVE



Characteristics

DESCRIPTION	iSWITCH iTOUCH lift button with capacitive button
REFERENCE	Recess model - DMTxAAG10303005 Surface accessory - CJACCTOUCHV0-1x
POWER	24 V =
CONSUMPTION	Maximun 125 mA
OUTPUT RELAY	<u>1 relay:</u> Free voltage relay . <u>Cutting power(max):</u> 12 A, 240 V~, cos φ = 1
PILOT LIGHTS	2 colors (red & green).
OPERATING TEMPERA-TURA	0°-50°.
BACK HOUSING	ABS Fireproof material (according to norm UL 94 V-0)

Dimensions:

Recess model

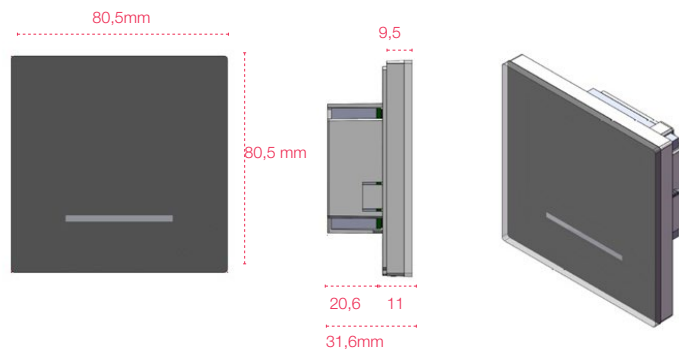

Surface model

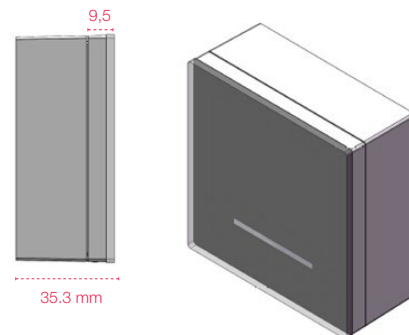

Features

LIFT BUTTON CONTROL Actives the lift's button by aproaching the hand.

CONTACTLESS. increased health and safety measures by avoiding the contact with the lift button.



Enkoa System S.L.

Polígono Erramone 45, 20850 Mendaro. Gipuzkoa. Spain
T +34 943 757 000 | info@enkoea.com
www.enkoea.com

