



iSWITCH

SISTEMAS DE GESTIÓN DE ENERGÍA ENERGY MANA- GEMENT SYSTEMS

Gateway

Enkoa's sensors are wireless and along with ENKOA wireless energy savers **enable saving up to 60% in the electricity bill** at the installed buidings.

Our products are designed to meet the needs of the following markets:

hotels/aparthotel, retirement homes, student housing, universities, office or government buildings...

**WE MAKE
SENSE**

ENKOA



Characteristics

DESCRIPTION	Gateway for iSWITCH wireless system
REFERENCE	PLCxI3P4
POWER	Power source. VIN: 85-264 VAC- 47-440 Hz VOUT: 5VDC/AW.
OUTPUT VOLTAGE	5VDC
LED COLOR	Red steady and multicolor led for some operations.
MEMORY	EEPROM external storage memory with 32 kbytes
DISPLAY	LCD, alphanumeric of 16 caracteres x 2 lines.
TECLADO	4 key matrix attached to the box to configure functions
COMMUNICATION INTER-FACE	Modbee (IEEE 802.15.4) /Ethernet
JOYSTICK	In the PCB to configure the functions
DIMENSIONS/ WEIGHT	208 mm (height) x 158 mm (width) x 83,5 mm (depth)/ 660 grs

Dimensions

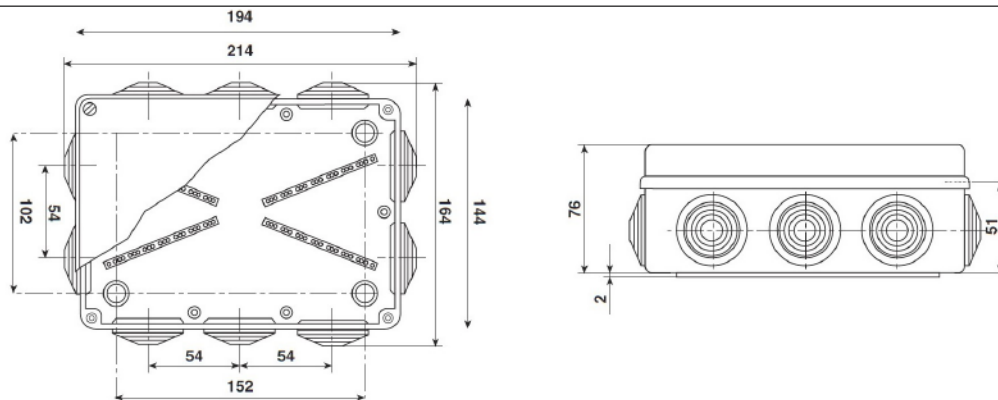

Benefits

WIRELESS COMMUNICATION WITH THE ENERGY SAVER.

It receives the room status from the energy savers and sends the information to the iVIEW software.

COMMUNICATION HUB It works as a link between the energy savers and the iVIEW software .

GATEWAY PER FLOOR

MAX. ELEMENTS : Up to 50 energy savers and 19 sensors per energy saver.